



**24" multi-touch monitor sa staklom od ivice do ivice, premazom protiv otisaka prstiju, podrška za aktivnu olovku (MPP 2.0) i fleksibilna podrška**

The ProLite T2255MSC with its Full HD (1920x1080) resolution and accurate PCAP 10 point touch technology, delivers a seamless and accurate touch response. Featuring IPS LCD screen technology, it offers exceptional colour performance and wide viewing angels. A special Nano coating ensures a smoother touch and less resistance in the swipe. It makes the screen less static and susceptible to dirt, dust and fingerprints. The monitor supports MPP2.0 (Microsoft Pen Protocol) technology, which is used in digital pens and styluses for use with compatible devices. The pen or stylus can interact with the ProLite T2255MSC, allowing users to write, draw, and navigate on the screen. It is very precise and supports tilt functionality, meaning the users can adjust the thickness and angle of their lines by tilting the pen, providing a more natural and intuitive writing and drawing experience. Its flexible stand can be positioned at several angles creating a comfortable and ergonomic user experience. A perfect choice for a vast array of creative applications.



MPP2.0 Podrška



Touch tehnologija - Kapacitivna

Ova tehnologija koristi senzornu mrežu mikro finih žica integriranih u staklo koje pokriva ekran. Dodir se prepoznaje jer se električne karakteristike mreže senzora menjaju kada se ljudski prst stavi na staklo. Zahvaljujući prekrivanju staklom ova je tehnologija vrlo izdržljiva, a funkcija dodira ostaje netaknuta čak i ako se staklo ogrebe. Nudi savršene performanse slike i radiče sa ljudskim prstom (takode i u rukavicama od lateksa) i olovkom.

## 01 KARAKTERISTIKE EKRANA

Dizajn	Staklo od ivice do ivice
Dijagonala	21.5", 54.5cm
Panel	IPS
Osnovna rezolucija	1920 x 1080 @60Hz (2.1 megapixel Full HD)
Osnovna rezolucija	60Hz
Format ekrana	16:9
Osvetljenje	400 cd/m <sup>2</sup>
Osvetljenje	360 cd/m <sup>2</sup> sa dodirrom
Propusnost svetla	90%
Statički kontrast	1000:1
Vreme odziva (GTG)	5ms
Zona gledanja	horizontalno/vertikalno: 178°/178°, desno/levo: 89°/89°, gore/dole: 89°/89°
Horizontalna sinhronizacija	30 - 83KHz
Vidljiva površina Š x V	478.7 x 260mm, 18.8 x 10.2"
Razmak piksela	0.249mm
Boja okvra	crna, mat

## 02 TOUCH

Touch tehnologija	projektivni kapacitivni
Tačke dodira	10 (HID, samo sa podržanim OS)
Preciznost dodira	+ - 2mm
Način dodira	olovka, prst, rukavica (lateks)
Interfejs dodira	USB
Podržani operativni sistemi	Svi iiyama monitori su Plug & Play kompatibilni sa Windows Linux operativnim sistemima. Detalje o podržanom OS-u za modele osetljive na dodir potražite u odjeljku za preuzimanje u uputstvima za instalaciju drajvera.
Odbijanje dlana	da

## 03 KONEKTORI / KONTROLE

Ulaz digitalnog signala	HDMI x1 DisplayPort x1
Audio izlaz	Mini konektor x1 Zvučnici 2 x 3W
USB HUB	x2 (3.2 Gen 1 (5Gbps, DC5V, 900mA))

## 04 KARAKTERISTIKE

Tvrdoća stakla	7H
Zaključavanje OSD tastera	da

## 05 OPŠTE

OSD jezici	EN, DE, FR, ES, IT, PT, RU, JP, NL, PL
Kontrolni tasteri	Džojstik: desno / meni / ulaz, levo / ulaz / izlaz, gore / eko, dole

## Korisničke kontrole

Podešavanje slike (osvetljenje, kontrast, i-Style Color, adv. kontrast, ECO, OverDrive, X-Res tehnologija), podešavanja boja (gama, RGB opseg, temp. boja), podešavanja slike (podešavanje video režima, reduktor plave svetlosti, oštar i mekan), OSD (horizontalni položaj, vertikalni položaj, vreme na ekranu, pozadina menija na ekranu, jezik, informacije o ekranu), ekstra (resetovanje, DDC/CI, izbor signala, jačina zvuka, utišavanje, logo za otvaranje, LED, prekidač na dodir)

Redukcija plavog svetla	da
Bez treperenja	da
Plug&Play	DDC2B

## 06 MEHANIČKI

Ugao nagiba	15° gore; 70° dole
VESA montiranje	100 x 100mm
MTBF - Prosecno vreme izmedju kvarova	50000 sati (izuzimajući pozadinsko osvetljenje)

## 07 UKLJUČENI DODACI

Kablovi Strujni kabl, USB, HDMI

## 08 UPRAVLJANJE NAPAJANJEM

Napajanje	interna
Potrošnja energije	% 1W tipično, 1.5W stand by, 0.3W iskljucen

## 09 ODRŽIVOST

Propisi	CE, TÜV-Bauart, EAC, RoHS podrška, ErP, WEEE, REACH, UKCA, cTUVus
Klasa energetske efikasnosti (Regulation (EU) 2017/1369)	D
REACH SVHC	iznad 0.1%: Olova

## 10 DIMENZIJE / TEŽINA

Dimenzije proizvoda Š x V x D	493.5 x 289.5 x 48.5mm
Težina (bez kutije)	3.2kg
EAN kod	4948570121625

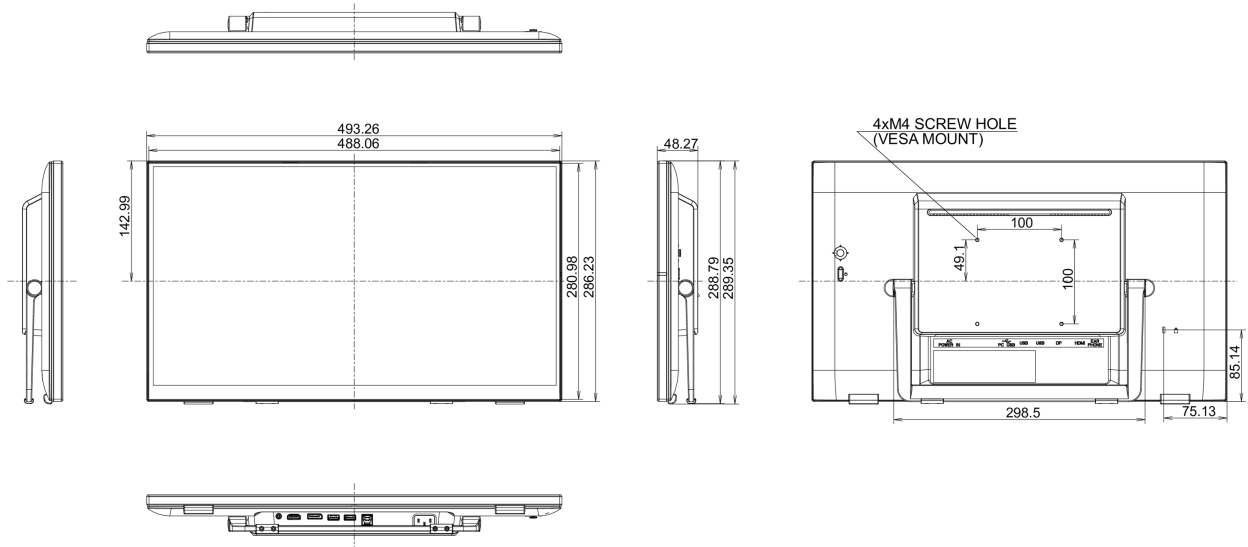

All trademarks and registered trademarks acknowledged. E & O E. Specification subject to change without notice. All LCD's comply with ISO-9241-307:2008 in connection with pixel defects.

© IYAMA CORPORATION. ALL RIGHTS RESERVED