

Wall lift for XXL format (touch) displays up to 180kg

This floor lift offers thanks to its three columns extra stability and robustness for working with a touch display. The display can easily be adjusted in height with the remote control, it adjusts it silently & electrically in height. At the back side of the mounting utility, space is reserved for placing a mini PC or thin client. This kit includes the adapter set [MD 052B7288](#).

01 SPECIFIKACE

Type	Nástěnný držák
Height adjustment	870mm, 936 - 1806mm
Váha max.	180kg / monitor
VESA maximum	800 x 600mm
Extra	electrical speed up to 38mm/s

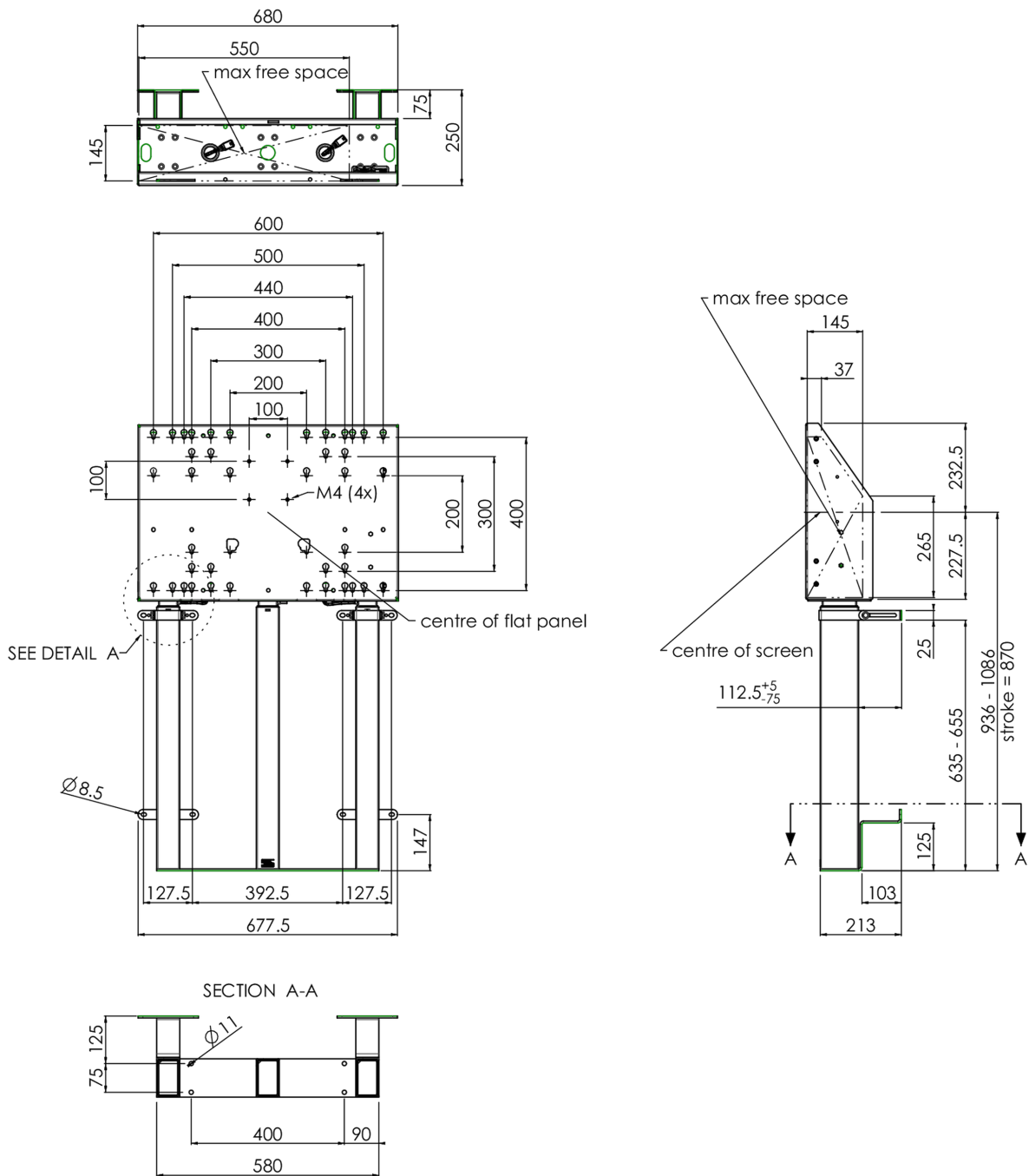

02 ROZMĚRY / HMOTNOST

Váha (bez balení)

45kg

EAN code

4948570032594

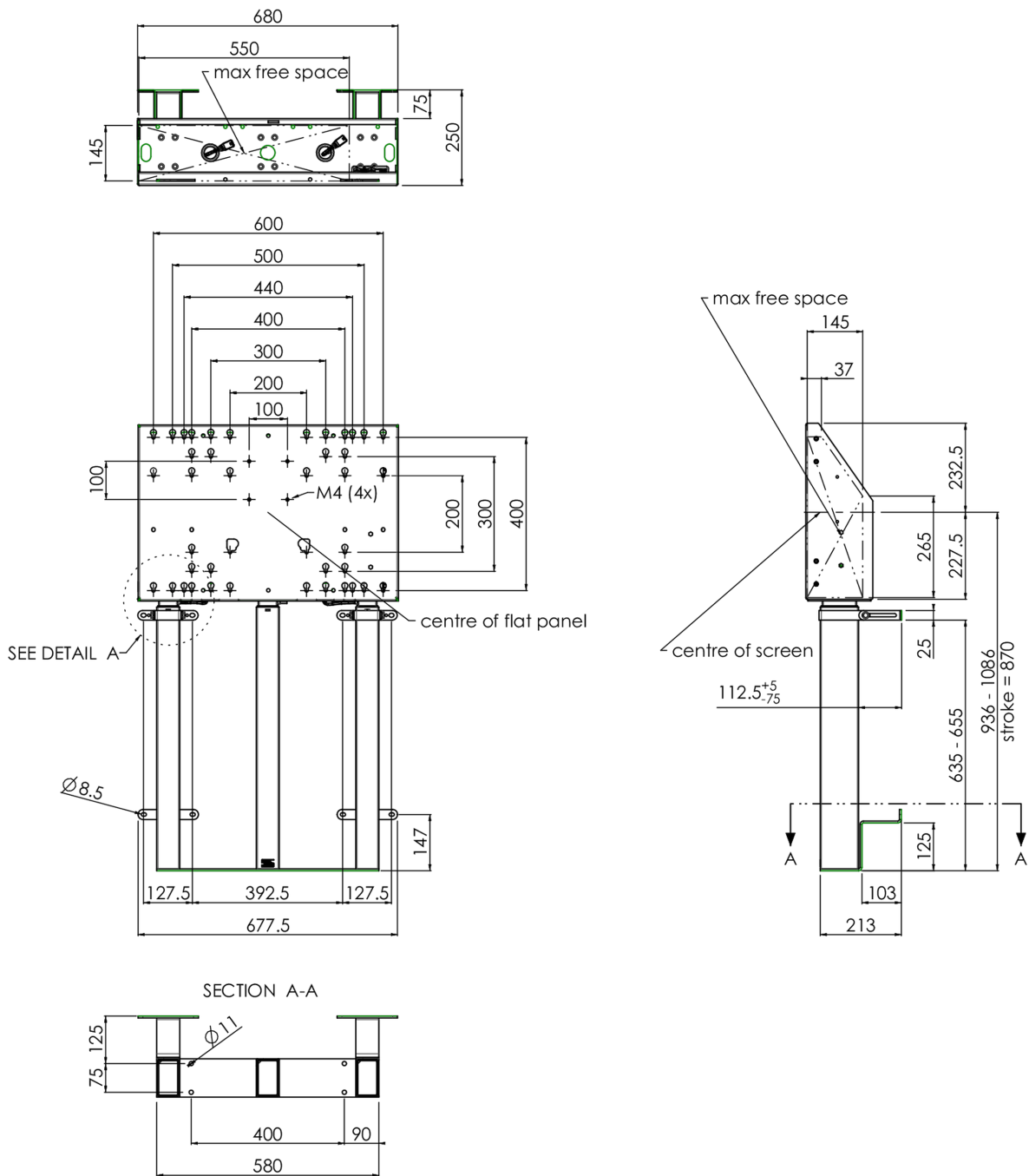

03 SOUVÍSEJÍCÍ INFORMACE

Související produkty

[MD 052B7285](#)

Všechny ochranné známky jsou registrovány a chráněny. Vyhrazené právo na změny. Veškeré ploché panely LCD splňují normu ISO-9241-307:2008 v oblasti počtu vadných pixelů.

© IYAMA CORPORATION. ALL RIGHTS RESERVED